

**DIAGNOSTIK**

**DIAGNOSTICS**

**DIAGNOSTIC**

**DIAGNÓSTICO**

**DIAGNOSTICA**

Blutdruckmessgeräte  
Sphygmomanometers  
Sphygmomanomètres  
Esfigmomanómetros  
Sfigmomanometri

DIAGNOSTIK

DIAGNOSTICS

DIAGNOSTIC

DIAGNÓSTICO

DIAGNOSTICA



02-1310-01

02-1311-02

02-1312-03



02-1350-03

02-xxxx-01

Mit Wickelmanschette aus Baumwolle komplett mit Latexpolster 2-Schlauch  
With cotton bandage cuff complete with 2-tube latex bladder  
Avec brassard en coton enveloppant complet avec vessie latex avec 2 tubes  
Con brazalete de venda de algodón, completo, con bolsa látex de 2 tubos  
Con bracciale di cotone a fascia, completo di camera d'aria in latex a 2 tubi

02-xxxx-02

Mit Hakenmanschette aus Baumwolle komplett mit Latexpolster 2-Schlauch  
With cotton hook cuff complete with 2-tube latex bladder  
Avec brassard en coton à crochets complet avec vessie latex avec 2 tubes  
Con brazalete de ganchos de algodón, completo, con bolsa látex de 2 tubos  
Con bracciale di cotone a ganci, completo di camera d'aria in latex a 2 tubi

02-xxxx-03

Mit kalibrierter Nylon-Velromanschette komplett mit Latexpolster 2-Schlauch  
With calibrated nylon velcro cuff complete with 2-tube latex bladder  
Avec brassard nylon-velcro, calibré, complet avec vessie latex avec 2 tubes  
Con brazalete velcro de nilón, calibrado, completo con bolsa látex de 2 tubos  
Con bracciale calibrato velcro-nylon completo di camera d'aria in latex a 2 tubi



02-1362-03

02-1363-03

02-1362-03

Mit kalibrierter Nylon-Velcromanschette mit Latexpolster 1-Schlauch  
 With calibrated nylon-velcro-cuff complete with 1 tube latex bladder  
 Avec brassard nylon-velcro calibré, complet avec vessie latex 1 tube  
 Con brazalete velcro de nilón, calibrado, con bolsa de látex con 1 tubo  
 Con bracciale calibrato velcro-nylon con camera d'aria di latex ad 1 tubo

02-1363-03

Mit kalibrierter Nylon-Velcromanschette mit Latexpolster mit Doppelschlauch  
 With calibrated nylon-velcro cuff complete with double tube latex bladder  
 Avec brassard nylon-velcro calibré, complet avec vessie latex double tube  
 Con bazelete velcro de nilón, calibrado, con bolsa de látex con doble tubos  
 Con bracciale calibrato velcro-nylon con camera d'aria di latex a 2 tubi

Blutdruckmessgeräte  
 Sphygmomanometers  
 Sphygmomanomètres  
 Esfigmomanómetros  
 Sfigmomanometri

DIAGNOSTIK

DIAGNOSTICS

DIAGNOSTIC

DIAGNÓSTICO

DIAGNOSTICA



02-1510-01

02-1511-02

02-1512-03

02-1510-01

Mit Wickelmanschette, Latexpolster 1-Schlauch  
 With Bandage cuff with latex bladder 1 tube  
 avec brassard enveloppant avec vessie latex 1 tube  
 con brazalete de venda con bolsa de látex 1 tubo  
 con bracciale a fascia con camera d'aria ad un tubo

02-1511-02

Mit Hakenmanschette, Latexpolster 1-Schlauch  
 With Bandage cuff with latex bladder 1 tube  
 avec brassard à crochets avec vessie latex 1 tube  
 con brazalete de ganchos con bolsa de látex 1 tubo  
 con bracciale a ganci con camera d'aria ad un tubo

02-1512-03

Mit kalibrierter Velcromanschette, Latexpolster 1-Schlauch  
 With calibrated velcro cuff with latex bladder 1 tube  
 avec brassard velcro calibré avec vessie latex 1 tube  
 con brazalete velcro calibrado con bolsa de látex 1 tubo  
 con bracciale velcro calibrato con camera d'aria ad 1 tubo

DIAGNOSTIK

DIAGNOSTICS

DIAGNOSTIC

DIAGNÓSTICO

DIAGNOSTICA

Stirnspiegel, Stirnlampe  
 Head Mirror, Head Lamp  
 Miroir frontal, Lampe frontale  
 Espejo, Lámpara frontal  
 Riflettore, lampada frontale

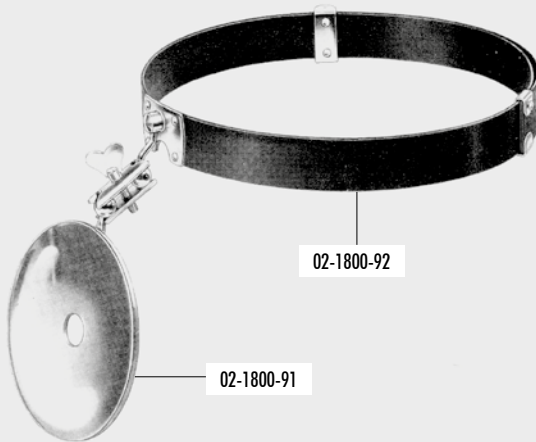

02-1800-91

02-1800-92

ZIEGLER compl.  
 02-1800-90

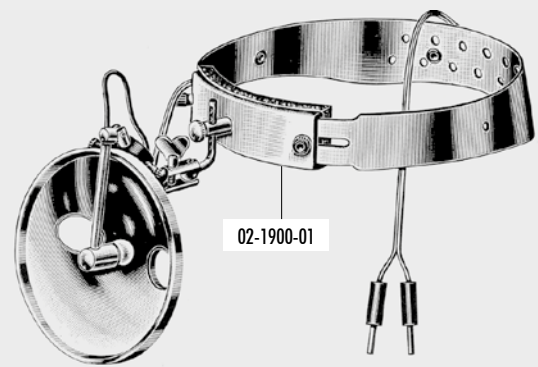

02-1900-01

CLAR 6 V compl.  
 02-1900-00

Dynamometer - Dynamometres - Dynamomètres  
 Dinamómetros - Dinamometri

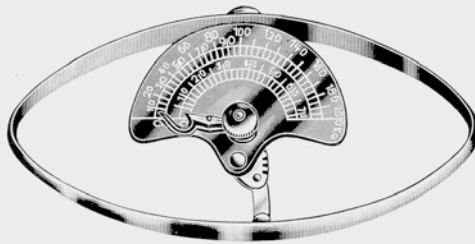

COLLIN

02-1600-01 Erwachsene · Adult · pour adultes · para adultos · per adulti

02-1600-02 Kinder · Child · enfant · niños · bambini

Venenstauer  
 Tourniquet  
 Tourniquet  
 Torniquete  
 Benda per emostasi

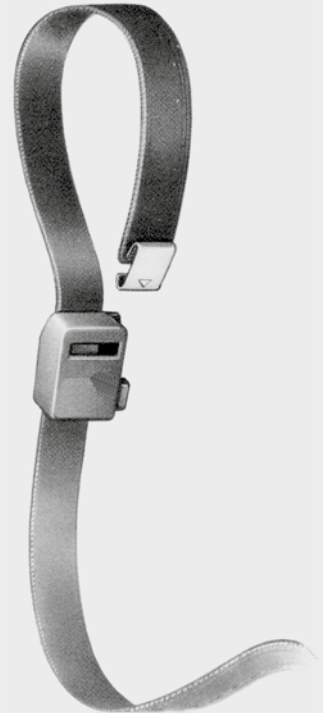

02-1607-00

Stirnlampe  
Head Lamp  
Lampe frontale  
Lámpara frontal  
Lampada frontale

DIAGNOSTIK

DIAGNOSTICS

DIAGNOSTIC

DIAGNÓSTICO

DIAGNOSTICA

Otoskop  
Otoscope  
Otoscope  
Otoscopio  
Otoscopio



02-1905-02

CLAR 6 V compl.  
02-1905-00



02-1905-01



6 Volt  
02-1909-06



02-2010-00

Konventionelle Beleuchtung  
2,7 V, mit Batteriegriff, für  
pneumatischen Test,  
Vergrößerung 4-fach, mit  
3 wiederverwendbaren  
Ohrtrichtern 2, 3 und 4 mm

Conventional Illumination  
2,7 V, Battery Handle, for  
pneumatic test, magnification  
4x, with 3 reusable ear  
specula  
2, 3, and 4 mm

Éclairage conventionnel 2,7 V,  
manche à piles, pour le test  
pneumatique, grossissement 4 fois,  
avec 3 spéculums auriculaires  
réutilizables 2, 3 et 4 mm

Illuminación convencional 2,7 V,  
mango de pilas, para el test  
neumático, ampliación 4 veces,  
con 3 espéculos auriculares  
2, 3 y 4 mm

Illuminazione convenzionale  
2,7 V, manico per batterie, per  
il test pneumatico, ingrandimento  
4 volte, con 3 specoli auricolari  
riusabili 2, 3 e 4 mm

Ophthalmoskop  
Ophthalmoscope  
Ophthalmoscope  
Oftalmoscopio  
Oftalmoscopio

## DIAGNOSTIK

## DIAGNOSTICS

## DIAGNOSTIC

## DIAGNÓSTICO

## DIAGNOSTICA

Oto-Ophthalmoskop  
Otoscope / Ophthalmoscope  
Otoscope et Ophthalmoscope  
Oftalmoscopio y Oftalmoscopio  
Oftalmoscopio e oftalmoscopio



MAY

02-2020-00

Konventionelle  
Beleuchtung 2,7 V, mit  
Batteriegriff,  
Korrekturlinsenwahl von  
0 bis +20 und 0 bis -20  
Dioptrien, mit Rheostat zur  
Lichtstärkeregelung

Conventional Illumination 2,7 V,  
with Battery Handle, Choice of  
corrective lenses from 0 to +20  
and 0 to -20 diopters, with  
rheostat to control light intensity

Éclairage conventionnel 2,7 V,  
manche à piles, choix de len-  
tilles de correction de 0 à +20  
et 0 à -20 D. Réglage continu  
de l'intensité de l'illumination  
par rhéostat

Iluminación convencional  
2,7 V, mango de pilas,  
Elección de lentes de  
corrección de 0 a +20 y  
0 a -20 dioptrías,  
intensidad de la luz  
regulable por reostato

Iluminazione convenzionale  
2,7 V, manico per batterie,  
scelta di lenti di correzione da  
0 a +20 e da 0 a -20 diottrie,  
illuminazione regolata mezzo  
reostato



02-2030-00

Konventionelle  
Beleuchtung 2,7 V, mit  
Batteriegriff,  
Otoskop und  
Ophthalmoskop siehe  
technische Daten  
02-2010-00 und  
02-2020-00

Conventional  
Illumination 2,7 V, with  
Battery Handle,  
Otoscope and  
Ophthalmoscope  
see technical data  
02-2010-00 and  
02-2020-00

Éclairage conventionnel 2,7 V,  
manche à piles,  
pour données techniques  
otoscope et ophthalmoscope voir  
02-2010-00 et  
02-2020-00

Iluminación convencional 2,7 V,  
mango de pilas,  
por datos técnicos otoscopio y  
oftalmoscopio véanse  
02-2010-00 y  
02-2020-00

Iluminazione convenzionale  
2,7 V, manico per batterie,  
per dati tecnici otoscopio e  
oftalmoscopio vedere  
02-2010-00 e  
02-2020-00



02-2050-00

Konventionelle Beleuchtung 2,5 V, mit Batteriegriff, Otoskop und Ophthalmoskop siehe technische Daten 02-2010-00 und 02-2020-00, Lampenträger verchromt, Nasenspekulum verchromt, 2 Kehlkopfspiegel Nr. 3 und 4, Spatelhalter

Conventional Illumination 2,5 V, with Battery Handle, Otoscope and Ophthalmoscope see technical data 02-2010-00 and 02-2020-00, with Bent-Arm Illuminator, Nasal Speculum chrome plated, Tongue Blade Holder chrome plated, with 2 laryngeal mirrors No. 3 and 4

Éclairage conventionnel 2,5 V, manche à piles, pour données techniques otoscope et ophthalmoscope voir 20-2010-00 et 20-2020-00, avec porte-lampe, spéculum nasal chromé, 2 miroirs laryngiens nos. 3 et 4, porte abaisse-langue chromé

Iluminación convencional 2,5 V, mango de pilas, por datos técnicos otoscopio y oftalmoscopio véanse 02-2010-00 y 02-2020-00, con porta-lámpara, espéculo nasal cromado, con 2 espejos laríngeos núms. 3 y 4, porta abaja-lengua cromado

Illuminazione convenzionale 2,5 V, manico per batterie, per dati tecnici otoscopio e oftalmoscopio vedere 02-2010-00 e 02-2020-00, con illuminazione a squadra, porta abbassa-lingua cromato, specolo nasale cromato, 2 specchietti laringei nro. 2 e 3

Diagnostikbesteck  
Diagnostic Set  
Trousse diagnostique  
Juego de diagnóstico  
Combinazione per diagnostica

DIAGNOSTIK

DIAGNOSTICS

DIAGNOSTIC

DIAGNÓSTICO

DIAGNOSTICA

Stethoskope  
Stethoscopes  
Stéthoscopes  
Estetoscopios  
Stetoscopi

DIAGNOSTIK

DIAGNOSTICS

DIAGNOSTIC

DIAGNÓSTICO

DIAGNOSTICA



FORD  
02-2402-00



DUPLEX  
02-2406-00

02-2600-15

fest  
fix  
fixe  
fijo  
fisso



02-2601-15

zerlegbar  
detachable  
démontable  
desmontable  
smontabile

cm PINARD ALU  
15,0 02-2600-15 - 02-2601-15



cm PINARD  
18,0 02-2602-18 Holz / wood / bois / madera / legno

15,0 02-2604-15 Kunststoff / plastic / plastique / plástica



DE LEE HILLIS  
02-2800-00

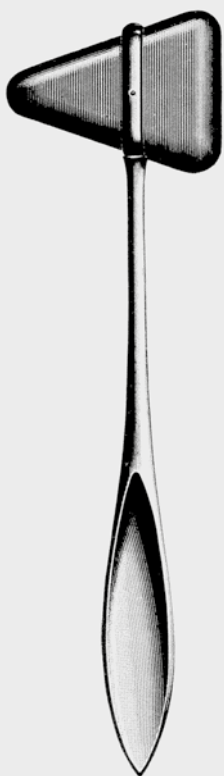

02-2808-29 grau / grey / gris / gris / grigio  
 02-2808-30 rot / red / rouge / rojo / rosso

cm TAYLOR  
 17,0 02-2808-17  
 20,0 02-2808-20

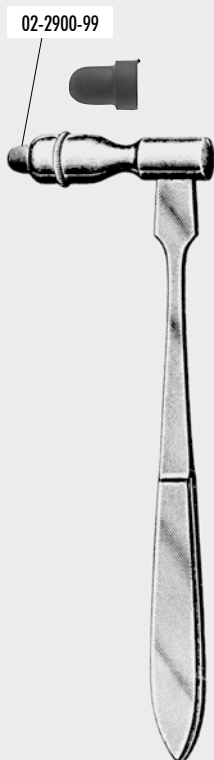

02-2900-99

cm TRAUBE  
 16,0 02-2900-16

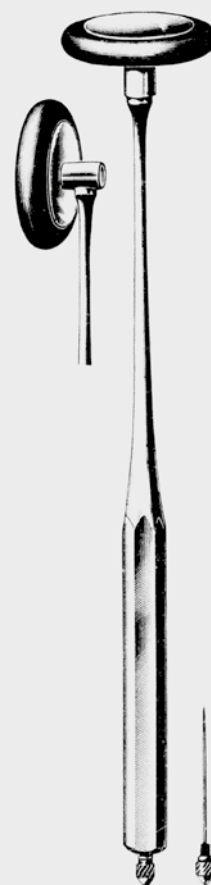

cm BABINSKY  
 22,0 02-2902-22

Perkussionshämmer  
 Percussion Hammers  
 Marteaux-percuteurs  
 Martillos de percusión  
 Martelli percussori

DIAGNOSTIK

DIAGNOSTICS

DIAGNOSTIC

DIAGNÓSTICO

DIAGNOSTICA

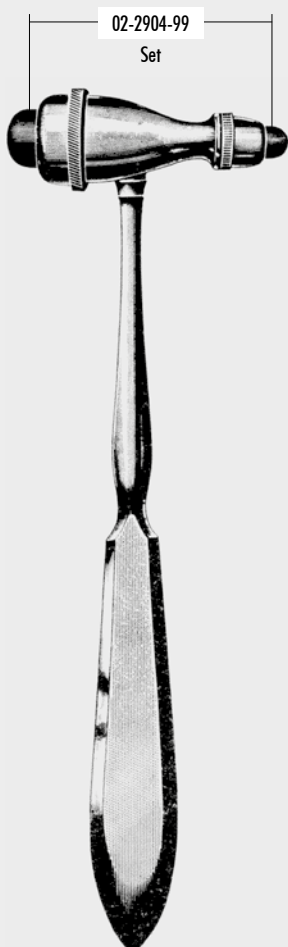

02-2904-99  
 Set

cm TROEMNER  
 24,0 02-2904-24

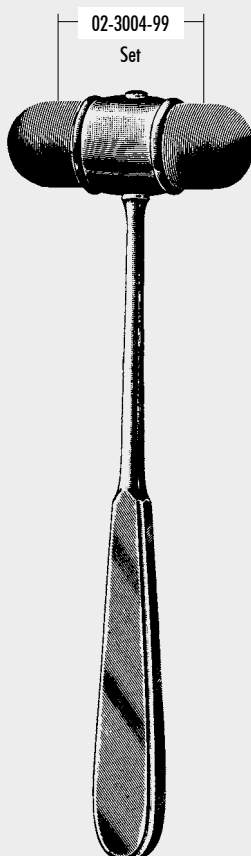

02-3004-99  
 Set

cm DEJERINE  
 20,0 02-3002-20

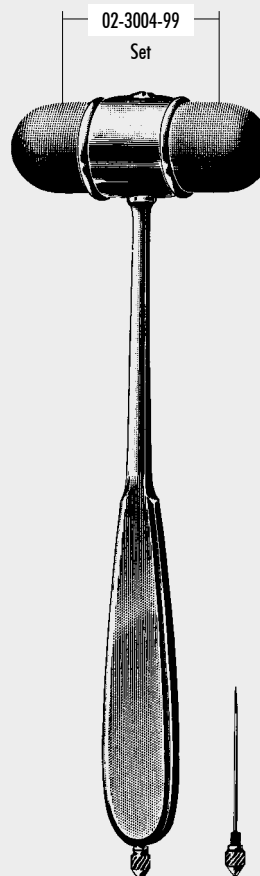

02-3004-99  
 Set

cm DEJERINE  
 21,0 02-3004-21

Perkussionshämmer  
Percussion Hammers  
Marteaux-percuteurs  
Martillos de percusión  
Martelli percussori

DIAGNOSTIK

DIAGNOSTICS

DIAGNOSTIC

DIAGNÓSTICO

DIAGNOSTICA

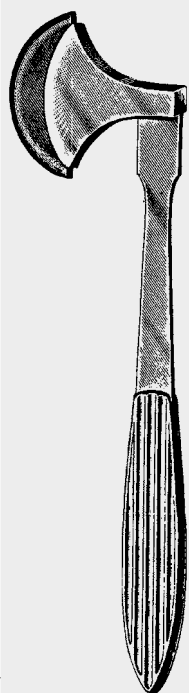

cm BERLINER  
17,0 02-3006-17

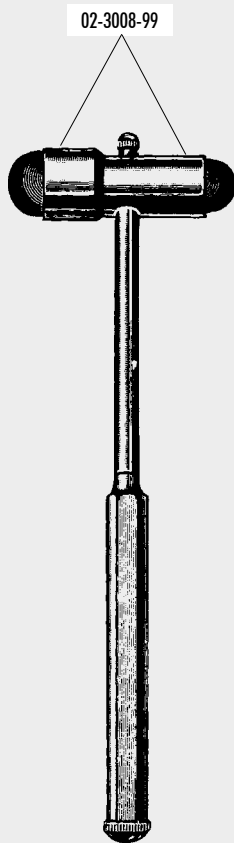

cm BUCK  
18,0 02-3008-18

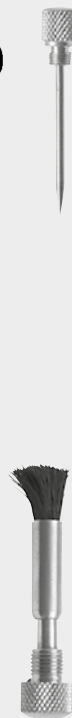

02-3008-98



02-3008-97



ø mm	NATIONAL HOSPITAL
50	02-3010-50
60	02-3010-60
70	02-3010-70
L = 35 cm	



BERTILLON  
02-3100-01  
Schädel-Messzirkel  
Cephalometer  
Céphalomètre  
Cefalómetro  
Cefalometro



MOELTGEN  
02-3102-01  
Winkelmesser  
Goniometer  
Goniomètre  
Goniómetro  
Goniometro



cm WEBER  
9,0 02-3106-09  
Ästhesiometer  
Aesthesiometer  
Esthésiomètre  
Esthesiómetro  
Esthesiometro



cm WARTENBERG  
19,0 02-3200-19  
Nadelrad  
Pinwheel  
Aesthésiomètre  
Sensiméto  
Sensimetro



cm	inch	
10,0	4	02-3400-10
15,0	6	02-3400-15
20,0	8	02-3400-20
25,0	10	02-3400-25
30,0	12	02-3400-30
40,0	16	02-3400-40
50,0	20	02-3400-50
100,0	39	02-3401-00
150,0	59	02-3401-50
200,0	79	02-3402-00



cm  
15,0 02-3404-15



1,5 m  
02-3502-15

Metall-Messstäbe, Maßband, Stahl  
Rulers, Metal, Tape Measure, Steel  
Règles, en métal, Ruban métrique en acier  
Reglas de metal, Cinta métrica de acero  
Regoli in acciaio, Nastro metrico in acciaio

DIAGNOSTIK

DIAGNOSTICS

DIAGNOSTIC

DIAGNÓSTICO

DIAGNOSTICA



Einteilung in mm und Zoll  
graduated in mm and inches  
divisé en mm et pouces  
graduado en mm y pulgadas  
diviso in millimetri e pollici

Messbereich bis 145 mm  
measuring range up to 145 mm  
pour mesurer jusqu'à 145 mm  
alcance de medición hasta 145 mm  
per misurare fino a 145 mm

cm  
22,5 02-3508-00

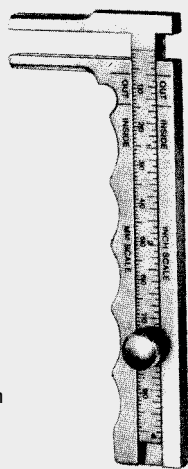

cm TOWNLEY  
10,0 02-3510-10



cm  
21,0 02-3512-21



cm VERNIER  
12,0 02-3514-12

Messschieber  
Calipers  
Pieds à coulisse  
Pies de rey  
Calibri



02-3400-10 - 02-3514-12



DIAGNOSTIK

---

DIAGNOSTICS

---

DIAGNOSTIC

---

DIAGNÓSTICO

---

DIAGNOSTICA

